



Anti-Slip Stair Treads

Product Information, Maintenance & Installation Guide

Product Description

GRP Anti-Slip Stair Tread Covers, designed to provide slip resistance to existing steps.

Product Properties

Safe Tread Anti-Slip Stair Covers are manufactured from high quality GRP incorporating either a **standard duty** quartz or **heavy duty** ToughGrip anti-slip surface.

TECHNICAL DATA	
Stock sizes	Length x depth x height (nosing): 600 x 345 x 55mm, approx. 2.21kg 750 x 345 x 55mm, approx. 2.76kg 1000 x 345 x 55mm, approx. 3.68kg 1200 x 345 x 55mm, approx. 4.42kg 1500 x 345 x 55mm, approx. 5.52kg 1800 x 345 x 55mm, approx. 6.62kg 2000 x 345 x 55mm, approx. 7.36kg 2400 x 345 x 55mm, approx. 8.83kg 3000 x 345 x 55mm, approx. 11.06kg 3660 x 345 x 55mm, approx. 13.5kg
Thickness	Standard Duty approx. 5mm Heavy Duty approx. 6mm Fine Grit approx. 4mm
Cut To Size	Free cut to size service maximum individual size 3660 x 345 x 55mm (nosing) Cutting tolerances +/- 3mm
Standard Duty	<ul style="list-style-type: none"> • Normal pedestrian traffic • Industrial applications. • Wet, frosty and oily conditions
Heavy Duty	<ul style="list-style-type: none"> • Busy pedestrian traffic • Industrial applications • Train stations, hospitals, stadiums, car parks, busy public walkways, stairways • Wet, frosty and oily conditions
Fine Grit	<ul style="list-style-type: none"> • Normal pedestrian traffic. • More sensitive areas such as play areas, schools • Wet and oily conditions
Environments	Indoor or outdoor use
Suitable Applications	<ul style="list-style-type: none"> • Staircases • Steps • Bridges • Access Platforms
Suitable Substrates	<ul style="list-style-type: none"> • Concrete • Wood • Metal • Steel • Chequer plate • Grating
Fixing Methods	Mechanically fixed or bonded with an adhesive (for extra security use both options) Free matching colour screws supplied (except Colourdec)
Service Temperature	-50°C to +80°C

COLOURS	
Stock DDA compliant	Black step Yellow nosing Black step White nosing Black step Orange nosing Dark Grey step Yellow nosing Dark Grey step White nosing
Single colours	Black RAL 9004 Medium Grey RAL 7004 Yellow RAL 1003 Brown RAL 8028 Buff RAL 1001
Non stock	Black step Grey nosing Black step Stone nosing Yellow step Black nosing
Colourdec	Barn Owl, Wizard, Gun Metal, Dune, Harvest, Woodland, Rustic, Bayside, Hillside, Vineyard, available with White or Black nosing

Slip Resistancy Test Results - Pendulum Test

Safe Tread Anti-Slip Stair Covers achieved the highest classification available of extremely low slip risk when subjected to the Pendulum test method. This method is the HSE's preferred method for assessing floor slipperiness in both dry and water wet conditions.

Pendulum test value readings - HSE 4S (slider 96)				
Type	Grit Grade	Dry	Wet	Greasy
Standard Duty Quartz	Medium	79	74	61
Heavy Duty ToughGrip	Coarse	82	80	64
Fine Grit ToughGrip	Fine	84	82	54
Colourdec	Medium	69	60	46

Product tested July 2016

Key	
Pendulum Value	Slip Potential
0-24	High
25-35	Moderate
36-64	Low
65+	Extremely Low

Tel: 01206 227 660 www.SafeTread.co.uk
Fax: 01206 866 666 email: info@safetread.co.uk



Anti-Slip Stair Treads

Product Information, Maintenance & Installation Guide

Visual contrast: Light Reflectance Values (LRV)

LRVs are specified in the DDA guidelines to ensure there is sufficient visual contrast for use by the partially sighted.

The LRV is a 100 point scale that expresses the percentage of visible light reflected by a surface at all wavelengths and in all directions, where 0 is complete black and 100 is complete white. In practice, black normally has a value of around 6 and white around 85.

Current regulatory guidance based on the final stage of the Disability Discrimination Act (DDA) says that a difference of 30 points or more in LRV is sufficient to provide reasonable visual contrast for the visually impaired, for example between a stair tread and its nosing.

Light Reflectance Values (LRV)		
Colour	LRV	DDA Compliant
Stair Tread White	72.5	✓
Stair Tread Yellow	40.8	✓
Stair Tread Black	4.5	✓

Maintenance and Cleaning

Cleaning

Use of a stiff brush will usually be sufficient to remove everyday dirt and debris. For more stubborn items a mild detergent can be used with warm water.

Prior to carrying out a full cleaning programme it's advisable to first test the suitability of the detergent on a small inconspicuous area.

Pressure Wash

If conditions allow, a pressure washer on a low setting can be used to clean the stair cover. However, if the stair cover has been secured with an adhesive agent or sealed with a sealant repeated use of a pressure washer could undermine the integrity of the adhesive / sealant.

Again, prior to carrying out a full cleaning programme it's advisable to first test the suitability of the pressure wash on a small inconspicuous area.

Spillages

Spills should be cleared up immediately. This should occur with consultation of product data sheets and in harmony with the company's own safety procedures.

General Routine Maintenance

The security of any fixings and the integrity of the products gritted surface and GRP substrate should be checked on a regular basis. The frequency of which will depend on the nature and volume of footfall. As a guide, for high traffic areas monthly inspections would be advisable.

Life Expectancy

Design life of 10+ years, subject to traffic analysis.

The life expectancy of any flooring product will be dictated by the nature and volume of the traffic it receives.

Factors such as shoe type and material, weight of individual, non pedestrian traffic, and any contamination such as dirt or grit are all factors that will influence the natural wear and tear of the stair tread cover.



Anti-Slip Stair Treads

Product Information, Maintenance & Installation Guide

Installation

Handling

Safe handling practices should always be employed. Store the covers flat upside down.

Cutting (where required)

We can do this for you, simply select the cut to size option and enter the exact sizes you require when you buy online.

Minor adjustments, small cut outs, can be made with a hacksaw or a jigsaw with a suitable blade.

Should you wish to cut yourself, Anti-Slip Stair Tread Covers can be easily cut to size using orbital cutting equipment with either a stone or diamond blade.

Cutting should be carried out externally or where there is dust extraction or suitable ventilation and appropriate protective equipment should be worn.

Fixing

We recommend a double fixing method for installing stair tread covers consisting of a high strength bonding adhesive and mechanical fixing to each end.

Having carried out adhesion tests using various adhesives we would recommend the use of Sikaflex for bonding our Stair Covers. Sikaflex is suitable for bonding to concrete, wood, metal and steel.

The reputation for Sika for quality and reliability is virtually unmatched, illustrated through a comprehensive portfolio of problem solving products that have been employed for many years in wide diversity of applications.

Sikaflex adhesive is also a sealant and can be used to seal around the edge to stop water lying between the stair cover and the substrate (water will not harm the stair cover but can affect wood or metal substrates causing rot or rust). Furthermore, use of Sikaflex will also help eliminate the drumming noise, when walked upon, that can be created when fitting onto an existing substrate.

Adhesive Quantity

As an approximate guide, with a 6mm bead 1 x 300 ml tube of Sikaflex should be sufficient to bond 3.5 linear metres of Safe Tread Anti-Slip Stair Cover.

Sikaflex adhesive can be purchased from Safe Tread: <https://www.safetread.co.uk/installation/adhesives>.

Technical data sheet for SikaFlex: https://www.safetread.co.uk/pdf/sikaflex_EBT.pdf

Preparation

Any damage or undulations to the receiving substrate should be remedied to ensure that the stair tread cover will be on a flat and even surface. When using an adhesive the substrate must be clean and dry, free from oils and grease, dust and loose particles. The underside of the stair tread cover must also be clean and dry. Where the substrate is contaminated (i.e. by oil or is wet) or its surface strength is wanting, mechanical fixing is essential. The installer should ensure that the substrate is of sufficient quality to achieve a secure fixing.

Prior to applying an adhesive it's advisable to first carry out a dry-fit to ensure a suitable fit.



Anti-Slip Stair Treads

Product Information, Maintenance & Installation Guide

Installation

How to install Anti-Slip Stair Tread Covers

1. Run a 6mm bead of adhesive around the perimeter of the stair cover about 25mm in from the edges and cross hatch at about 200mm apart.

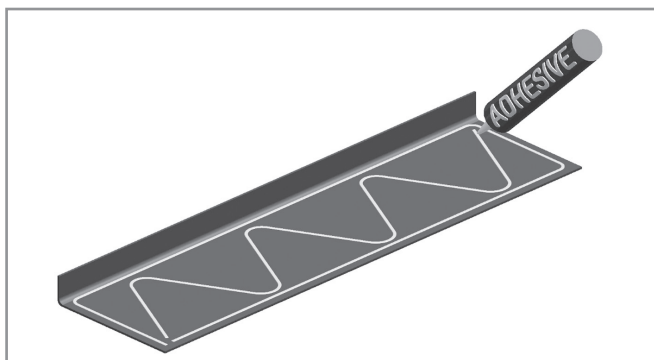

2. Use hand pressure to bed the stair cover into position.
3. Fixing is generally recommended at approx 70mm from the front, 60mm from the back, 50mm from each side. We recommend a maximum of 500mm between fixings.
4. Secure with pozi self-tapping stainless steel screws supplied or with your own fixings should these not be suitable for the installation substrate.

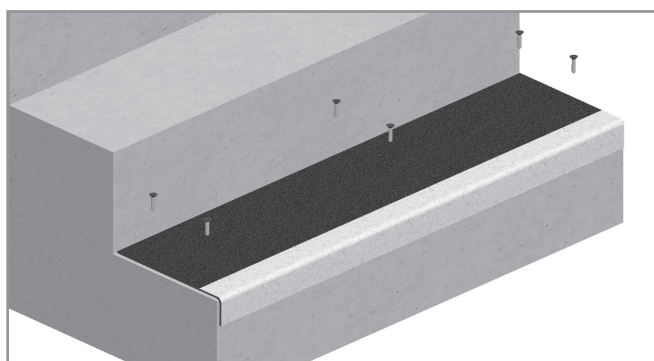

Stairs can be used immediately.

Bonding only

With Sikaflex optimum bonding will be obtained around 48 hours after application at 23°C. However, the stairs can be opened to traffic a few hours after bonding subject to temperature.

Mechanical fixing only

Fixing is generally recommended at approx. 70mm from the front, 60mm from the back, 50mm from each side. We recommend a maximum of 500mm between fixings.

Installation video

All you need to know in just over a minute:
<https://www.safetread.co.uk/tvid>



HANDY ADVICE

If steps are heavily worn consider using Riser Plates to give extra support.

Miscellaneous

The installation instructions make no claim to being comprehensive but should be used as a guide. Always employ safe practices. It's recommended that to first test the suitability of any fixing method on a small area before carrying out a full installation programme.

Other Non Slip Stair & Floor products from Safe Tread:

- Non-Slip Decking Strips • Non-Slip Floor Sheets
- Anti-Slip Stair Nosing • Anti-Slip Extra Deep Stair Treads
- Stair Riser Plates • Anti-Slip Stair Tactiles
- Installation Tools, Screws, Adhesives



ISO 9001



ISO 14001

